

AERIS SERIES DINING TABLES

PBJ

EST. 1968



The AERIS dining table has an elegant, classic look with a modern touch. The top plate is "floating" over the rounded legs, which has a nice detail near the top. The table comes in both rectangular and round versions.

Cookes | LIFE well furnished

Designed by
Morten Svendsen





AERIS dining table

No 738175 - 175 cm

No 738220 - 220 cm

Rectangular dining table with possibility for extension in each end. 8-12 or 10-14 seats - extended 12-16 or 14-18 seats.

L 175 W 95 H 75 cm.

L 220 W 95 H 75 cm.

Extension and storage to be ordered separately.

No 7388060 - 1 pcs. extension leaf.

No 7386010 - 1 pcs. storage

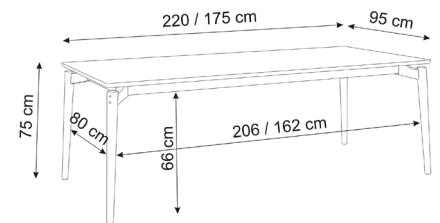

AERIS round dining table

No 738105 - D 105 cm

- 4 seats. Max 1 ext.

No 738122 - D 122 cm

- 4 seats. Max 2 ext.

NO 738140 - D 140 cm

- 8 seats. Max. 2 ext.

Round dining table with possibility for extension in the middle. Each extension leaf gives 2 extra seats.

Extension leaf has to be ordered separately.

No 738052 - 1 extension leaf to D 105.

No 738063 - 1 extension leaf to D 122.

No 738064 - 1 extension leaf to D 140.

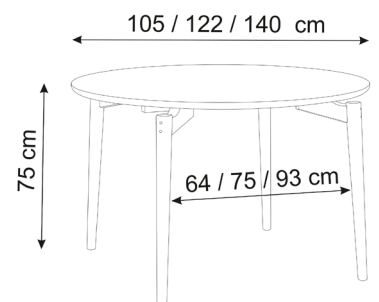

AERIS SERIES

AERIS dining table has an elegant, classic look with a modern touch. The top plate is "floating" over the rounded legs, which has a nice detail near the top. The table comes in both rectangular and round versions. You can get a magazine to mount under the rectangular table - now it is easy to store your extension leaves. You can choose the table in a lot of beautiful colors, please see below.



COLOURS AND MATERIALS

BASE, FRAME AND CABINET

VENEER



43 Light oak mat lac



45 Oak natural oil



49 Smoked oak mat lac



87 Black oak mat lac



75 Walnut oil

TABLETOP

VENEER



43 Light oak mat lac



40 Light Oak herringbone



45 Oak natural oil



75 Walnut oil



70 Walnut herringbone



87 Black oak mat lac

SOLID



46 Oak Natural Oil

HPL LAMINAT



101 White



110 Seed



128 Earth



131 Storm



184 Nero Stone

FENIX (NANO) LAMINATE



201 Bianco White



204 Deep Black



210 Dark Warm Grey



219 Verde



222 Grigio

ARPA (MARBLE) LAMINATE



301 Yule White



302 Yule Grey



303 Pulpis Light



304 Pulpis Dark

QUALITY FURNITURE SINCE 1968

PBJ Designhouse was founded in 1968 by Per Buhl Jørgensen. Since 1996 the proud design and craftsmanship tradition has been carried on by Morten Svendsen, and the company has invested in larger production facilities to follow the strong demand.

DANISH DESIGN

PBJ Designhouse has a tradition of bringing together furniture architects and certified cabinet makers since the start.

This has turned the company into an exponent of Denmark's proud traditions in furniture – when creativity and quality unite, the result reaches new heights.

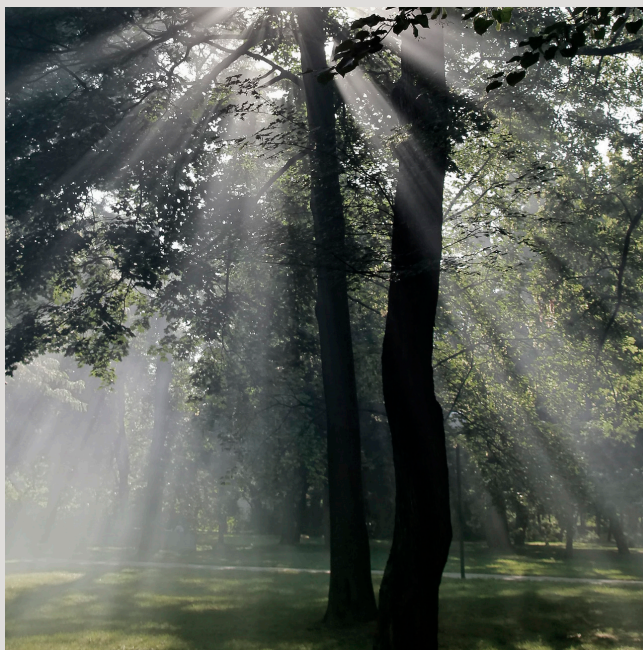

FURNITURE WITH A CONSCIENCE

All wood used at PBJ Designhouse comes from state approved plantations, where the logs are individually selected and gently harvested.

We often produce furniture with veneer. The reason for this is twofold. It reduces the use of solid timber, thereby conserving natural resources. Secondly, the MDF that the veneer cover is made with recycled wood which is better for the environment whilst still producing a strong and high-quality surface.

All of our timber and veneer are carefully hand sorted so that the grain patterns and color variations are as natural as possible.

The brochure is subject to technical changes and possible printing errors.

